



Colorado Water Fountain

Floor Mounted

# Colorado Floor- Standing Drinking Water Fountain

Compact drinking fountain, delivering chilled water.

- Minimal usage of space
- Adjustable temperature
- Easy maintenance



## Product features and benefits



### Minimal usage of space

This simple, compact unit is sure to fit in with any environment - the cabinet occupying only one square foot. Supplied with a bubbler valve, this fountain is suitable for direct sipping, perfect for keeping you hydrated on the go.



### Adjustable temperature

The system has a built in pressure vessel, which ensures that the chilled water is dispensed every time with its temperature ranging from 2 - 11 degrees, based on the adjustable thermostat.

20  
L/HR

FLOW RATE

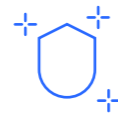

### Easy maintenance

The system has a robust stainless steel finish making it easy to wipe down and maintain, it also has a removable front for service and maintenance convenience.



The addition of an optional swan neck tap makes this a handy glass/ bottle filling station as well.



## Technical specifications

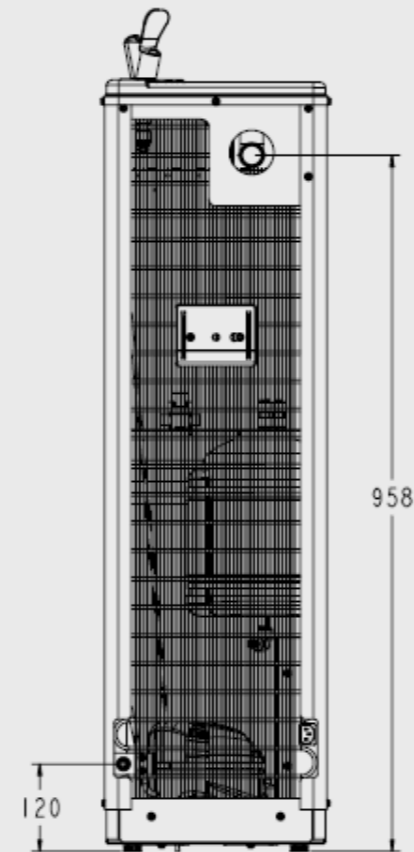
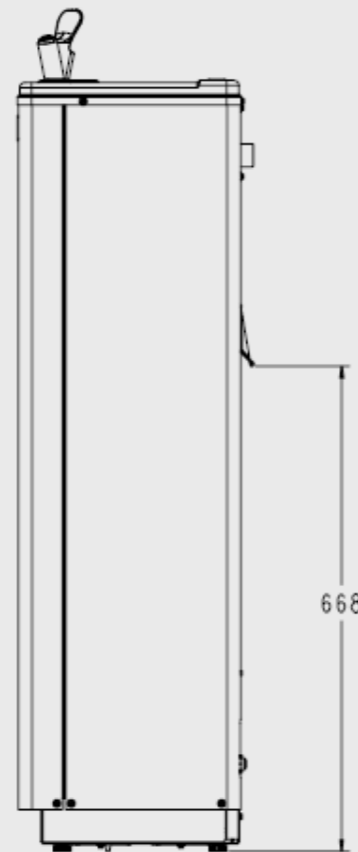
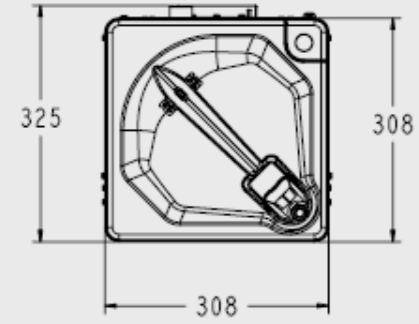

## Specifications

Model	Floor standing
Filtration	Built-in 100 micron strainer
H x W x D (mm)	310 x 1020 x 310
Dispensing Area Height (mm)	
Waste Option(s)	
Weight (kg)	22
Chilled Water Production	20 Litres per hour
Water Temperature	
Rated Input	
Water Temperature	2-11 Degress C
Features	

## Installation requirements

Power supply	220-240V, 50/60Hz
Water supply	
CO2 Gas	N/A
Mains waste	
Ventilation	
Ventilation Comments	

## Water options

Ambient	Cold	Hot
	