

OAS035

# OASIS

## F100 WALL-MOUNTED DRINKING FOUNTAIN



The F100 Wall-Mounted Drinking Fountain is designed with an Anti-Splash Ridge to ensure a mess-free drinking experience.

It is available in either a Stainless Steel finish or optional Regency Bronze at an additional cost, making it the ideal solution for those looking for a low-cost hydration option.

Suitable for both indoor and outdoor use, this WRAS-approved model is sure to meet your needs.

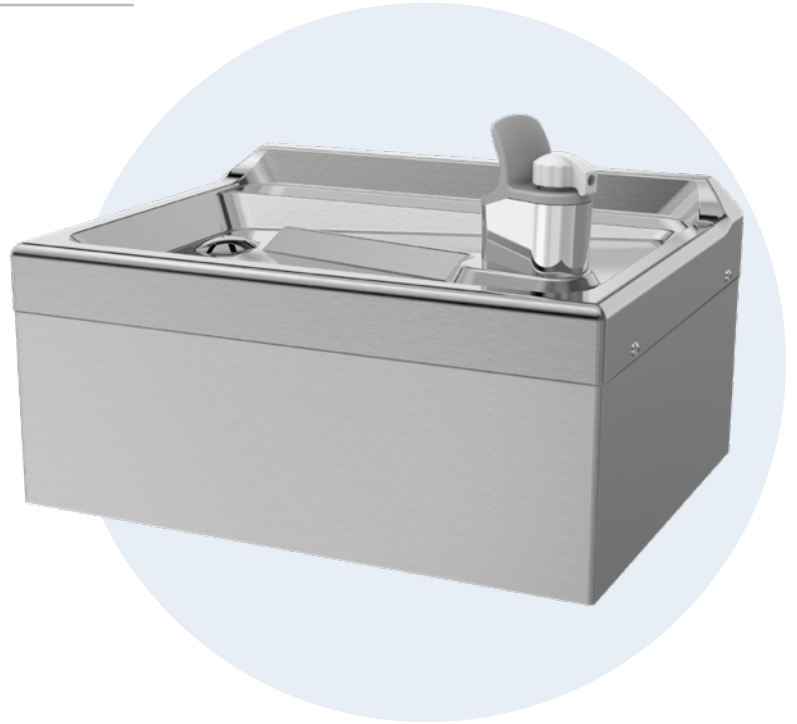

### AVAILABLE OPTIONS:



AMBIENT WATER



BUILT-IN 100 MICRON STRAINER FILTRATION

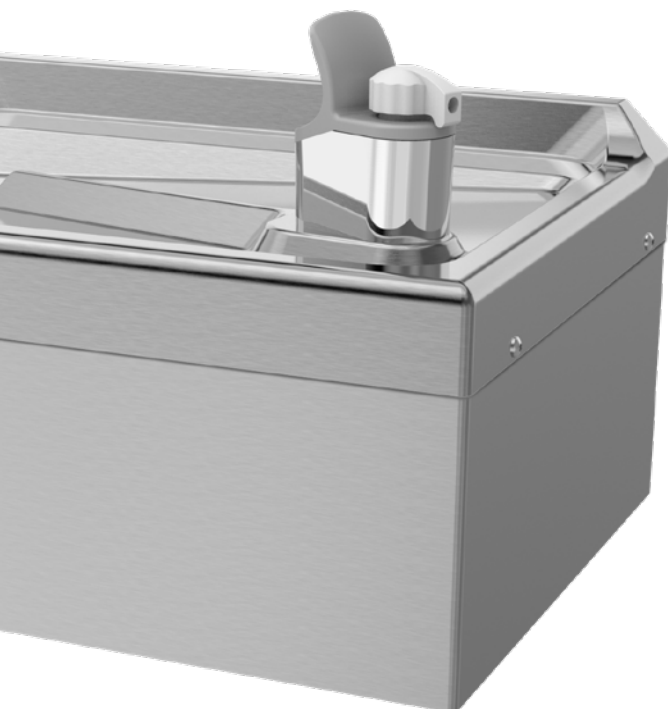

Waterways are lead-free ensuring optimum safe water



Suitable for public building, gymnasiums, sports complexes, hospitals, schools and offices



Anti-Splash Ridge ensures a mess-free drinking experience



Ideal for those looking for a simple, low-cost hydration solution

<b>DIMENSIONS</b>	432W x 331D x 225H mm
<b>INSTALLATION</b>	Suitable for indoor or outdoor installation
<b>WEIGHT</b>	7kg
<b>WATER OPTIONS</b>	Non-chilled / ambient
<b>CERTIFICATION</b>	NSF Certified (lead free)
<b>ACTIVATION</b>	Mechanical (Dial-A-Drink Adjustable Bubbler with Flexible Bubbler Guard)
<b>FILTRATION</b>	Built-in 100 micron strainer, Green Filter (optional)
<b>COLOUR / FINISH</b>	Brushed Stainless Steel



### Culligan brand

At Culligan, we only provide the best tried-and-tested sustainable hydration solutions available. This product belongs to the Culligan family of trusted brands.



### Space-saving

The Oasis F100 Wall-Mounted Drinking Fountain is a compact, surface drinking water fountains that is ideal for those smaller environments where space-saving is essential.

